

THE INHIBITION OF DROPLET DEPOSITION BY THE PRESENCE OF A LIQUID WALL FILM

M. M. LEE and T. J. HANRATTY

Department of Chemical Engineering, University of Illinois, Urbana, IL 61801, U.S.A.

(Received 23 October 1986; in revised form 25 October 1987)

Abstract—A study has been made of the effect of the boundary on the rate of depositions of 50 μm water droplets that are injected from a centrally located tube into air flowing downward in a 50.8 mm pipe at a Reynolds number of 30,600. Three wall conditions were used: (1) grounded brass; (2) Plexiglas; and (3) Plexiglas wetted with a downward flowing relatively smooth water film with a thickness of 155 μm . Deposition rates were about the same for the brass and Plexiglas walls. The presence of the water film on the wall was found to impede deposition, possibly by promoting droplet bouncing.

1. INTRODUCTION

Droplets carried by a turbulent gas stream flowing through a pipe deposit on the walls by mechanisms which are not completely understood. There is considerable interest in this phenomenon because of its importance in predicting entrainment in annular gas-liquid flows (Hewitt & Hall-Taylor 1970; Andreussi *et al.* 1985b) and in predicting "dryout" or "burnout" in vertical heated tubes through which a liquid is flowing (Hewitt & Hall-Taylor 1970; Hewitt 1981). This paper presents results which suggest that a thin liquid film flowing along the wall can, under certain circumstances, greatly impede the deposition process.

Experiments similar to those described by McCoy & Hanratty (1979) were performed in a vertical pipe through which air flowed in a downward direction. Droplets, 50 μm dia, were tagged with dye and injected in the air stream at the center of the pipe. Three types of experiments were performed: in the first, a Plexiglas pipe wall was covered by a continuous falling film, which was sufficiently thin that no atomization occurred (Andreussi *et al.* 1985a; Woodmansee & Hanratty 1969); the second used this same test section without a falling film; and the third used a dry wall consisting of eight sections of brass pipe, which were electrically grounded to eliminate the possibility of the buildup of electrostatic charges, and one section of Plexiglas at the downstream end for visual observations.

In the runs with a wetted wall samples of the liquid film were withdrawn at various axial locations. The rate of droplet deposition per unit area was determined from measurements of the change of dye concentration in the film samples and of the film flow rate.

In the experiments with a dry wall the droplets that deposited on the wall formed streaks which evaporated to leave behind a dye mark. After the droplet injector had operated for some fixed time period, the dye marks on different sections of the pipe wall were washed off with a known amount of water. Samples of these washings were analyzed with a u.v. spectrophotometer for dye concentration to give the amount of dye deposited on a section in a given time period. From this result and measurement of the dye concentration in the injected drops, the rate of droplet deposition per unit area could be calculated.

2. DESCRIPTION OF EXPERIMENTS

(a) *The flow system*

The experiments were performed in the 50.8 mm flow system shown in figure 1. The droplets were injected at approximately the air velocity at a location that was sufficiently downstream from the entrance for the air flow to be fully developed.

The injection system, which is described in detail in theses by Vames (1985) and Lee (1984), is shown in figure 2. A liquid jet for the production of droplets is created by forcing water through

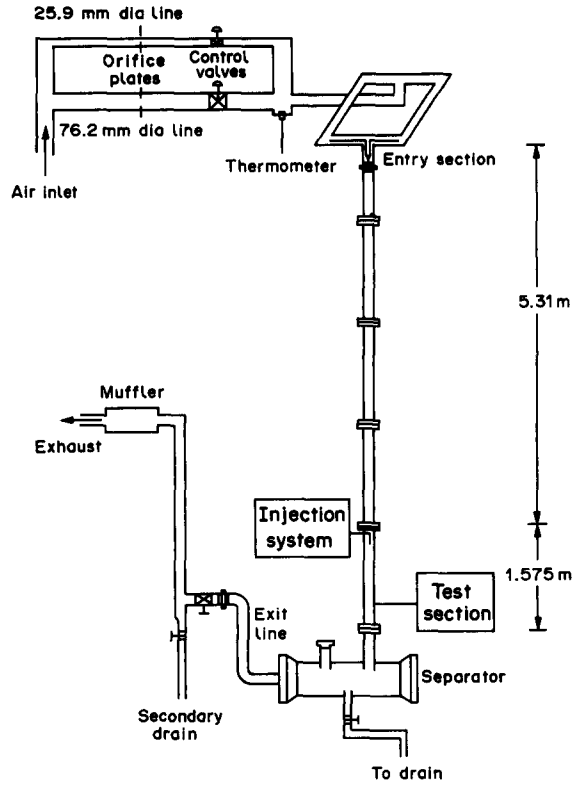

Figure 1. Flow system.

a small circular orifice at the tip of a stainless-steel tube that is electrically grounded. Distilled and deionized water is supplied from a 2500 ml brass reservoir that is pressurized with air. The water flows through a $0.2 \mu\text{m}$ pore size mini capsule filter before entering the droplet generation chamber. In this chamber, a Bimorph transducer disturbs the liquid flow in such a way as to produce a stream

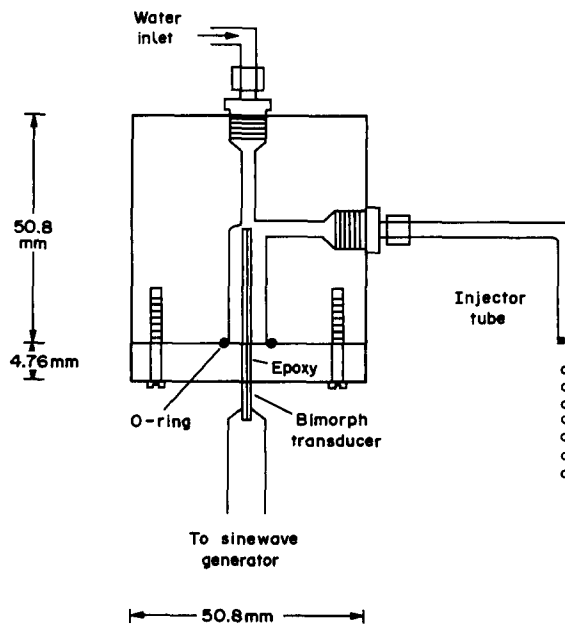

Figure 2. Droplet generator.

of droplets as the water leaves the injector tube. The $38.1 \times 3.18 \times 0.533$ mm Bimorph, manufactured by Vernitron, consists of two thin, silver electrodes sandwiched together and polarized in opposite directions. The application of an electric field across the two electrodes causes one layer to expand while the other contracts. Reversing the direction of the electric field causes the transducer to bend in the opposite direction.

Rayleigh demonstrated that a laminar jet exposed to a periodic disturbance of the appropriate frequency breaks up into a stream of uniform droplets. Schneider *et al.* (1967) defined the maximum instability frequency (in Hz) as

$$f_m = \frac{v_j}{4.06d_j}, \quad [1]$$

where v_j is the jet velocity and d_j is the jet diameter. A disturbance in the frequency range of f_m to $0.24f_m$ applied to a water jet produces droplets of diameter

$$d_p = \left(\frac{6Q}{\pi f} \right)^{1/3}, \quad [2]$$

where Q is the volumetric flow rate of the jet and f is the frequency of the applied disturbance. This technique has been successfully employed by a number of investigators, including McCoy & Hanratty (1979), Tattersson (1975) and Ginsberg (1970).

Vames (1982) fabricated a droplet generator based on a design suggested by Adam *et al.* (1971). The generator chamber (see figure 2) was machined from a $50.8 \times 50.8 \times 25.4$ mm block of Plexiglas. Water is forced through the inlet and out through an injector tube after being disturbed by the vibrations of a PZT-5H Bimorph piezoelectric transducer. The vibrations of the Bimorph, at a frequency prescribed by an applied sinewave signal, are transmitted through the water in the generator chamber to the surface of the liquid jet issuing from the injector orifice.

The injector orifice, developed by Lee (1984), consists of a thin cross section of a glass capillary which is fastened to the end of the stainless-steel injector tube with a clear glass adhesive. The glass was ground to a thickness < 1 mm to minimize pressure losses and polished on both sides so that the edges of the orifice were smooth. This injector design produces stable streams of uniform droplets directed perpendicular to the plane containing the injector tip. The glass capillaries used in this work had an orifice dia = $25.4 \mu\text{m}$.

The water that flowed to the injector was mixed with diluted No. 521 Graphic Controls black recorder ink, whose rate was monitored by a Gilmont flowmeter. The use of a 60 W light bulb directly behind the flowmeter facilitated the reading of the meter since the shadow of the glass float could then be observed.

(b) Experiments with a wetted wall

A schematic of the test section used in the experiments with a wetted wall is shown in figure 3. The total length was 2.978 m.

The liquid film entry unit, shown in figure 4, was located just above the test section. It had a slot with a 30° wedge. When the water in the annulus surrounding the pipe rose above this wedge, it overflowed into the test section.

The distance between the droplet injection and the slot for entry of the liquid wall film was 0.337 m. Measurements of droplet dispersion by Vames (1985) in this same system indicated that droplets first reached the wall downstream of the slot for film entry.

Because the water flow rates were very small the water flowed down untreated Plexiglas as rivulets. A technique developed by Tattersson (1975) was used to improve the wettability of the wall. The pipe wall was roughened and a hydrous tin oxide colloid was applied. This was allowed to dry so that the colloid adhered to the walls permanently. After this treatment a completely wetted wall could be obtained with film flow rates as small as 4.3×10^{-3} kg/s.

The film flow rate used in the experiments was such that the film Reynolds number, defined as $4Q/\pi d_i \nu$, was equal to 146. Here Q is the volumetric flow, d_i is the pipe diameter and ν is the kinematic viscosity. The height was calculated to be $155 \mu\text{m}$ with the equations developed by Andreussi *et al.* (1985a). Because of the effect of interfacial shear this is smaller than the value of $240 \mu\text{m}$ calculated for a free-falling film. Figure 5 shows measurements obtained by Henstock

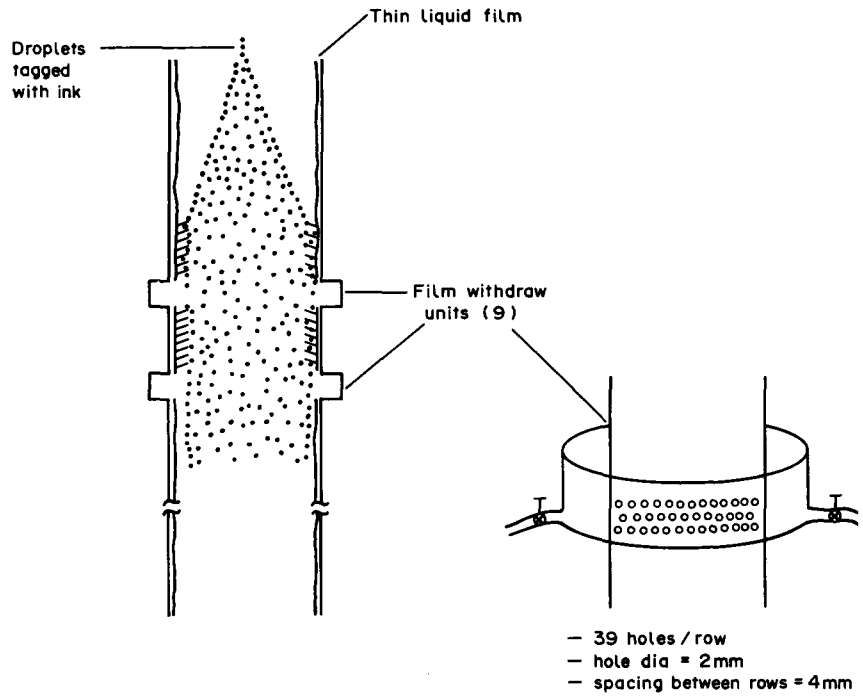

Figure 3. Test section used in experiments with a wetted wall.

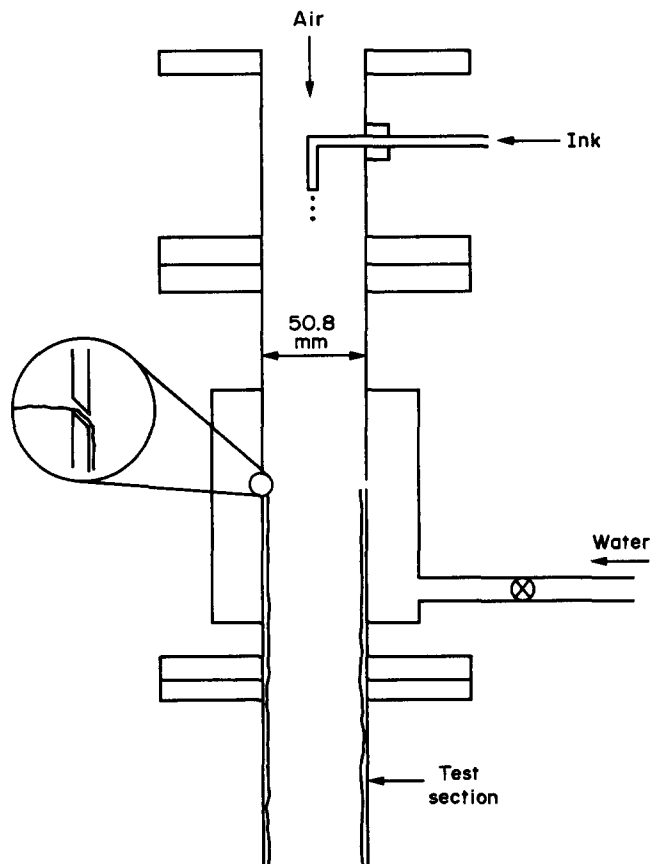

Figure 4. Film entry unit.

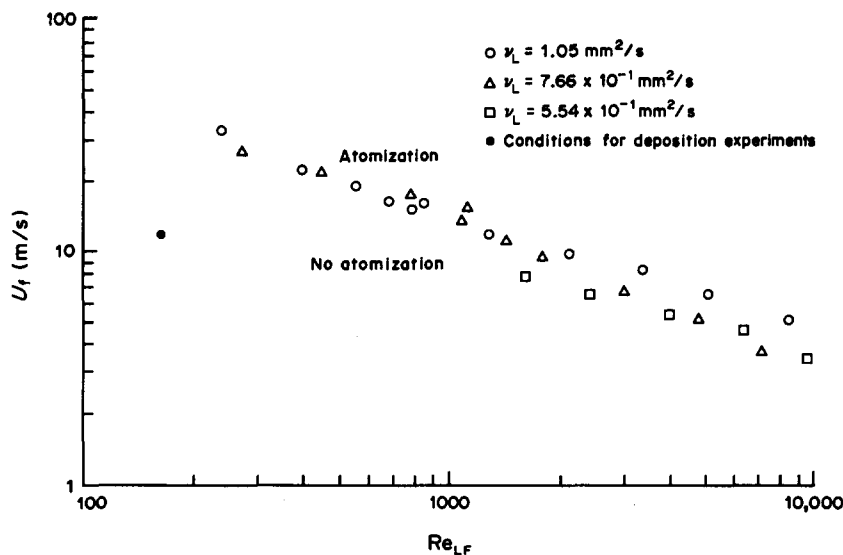

Figure 5. Film flow condition used in deposition studies.

(1977) of the conditions required for the initiation atomization for downward flow in a pipe. These indicate that the film flow was well below that required for atomization.

Nine film withdraw units, of the type shown in figure 3, were separated by a distance of about 0.254 m. Each of these consisted of three rows of holes around the circumference of the pipe, with a spacing of 4 mm between the rows. There were 39 2 mm holes in each of these rows. These were arranged in a staggered fashion so that the liquid film has an equal chance of leaving the pipe anywhere along the pipe wall. The three rows of holes were enclosed by a Plexiglas collar which had two exiting valves.

When the valves were opened the pressure of the gas forced the liquid out of the pipe into a sampling bottle. This required that a throttling valve be placed at the exit of the pipe so that the static pressure could be set at 64.7 mmHg. At this pressure only about 60% of the liquid film could be withdrawn.

(c) Experiments with a dry wall

The test section used to study deposition on a dry grounded wall consisted of eight sections of brass pipe, 0.330 m long, followed by a 0.3366 m length of Plexiglas pipe. The ends of the different sections were machined with 3° tapers to ensure smooth transition at the pipe joints. The sections were connected by flanges that used a tongue-and-groove configuration to match them exactly.

A liquid film was allowed to flow along the wall to wash away ink that reached the wall during the initial procedures involved in centering the injector and in adjusting the injection system in order to obtain the desired droplet size. A slight modification of the droplet injection system was used in these experiments to prevent the injection of droplets into the pipe during the period (after the discontinuance of the film flow) when the pipe wall was drying. As shown in figure 6, provision was made for a Plexiglas block, with a circular cavity, to be pushed into a position under the injector tip to collect droplets. A 2.38 mm dia hole was drilled from the handle of the block to the cavity so that suction could be applied to remove the ink solution from the cavity. The length and curvature of the Plexiglas block were machined so that the block was exactly flush with the pipe wall when it was pulled out. Before starting the experiment the brass pipe was grounded and it was checked that the wall was completely dry by observing the Plexiglas section.

An experiment lasted for 15–20 min. At its termination the Plexiglas block was again pushed back into the pipe to collect the ink droplets. The flows of air and ink solution were then turned off. The nine sections of pipe, now covered with ink marks, were disassembled and washed to determine the amount of ink that had been deposited.

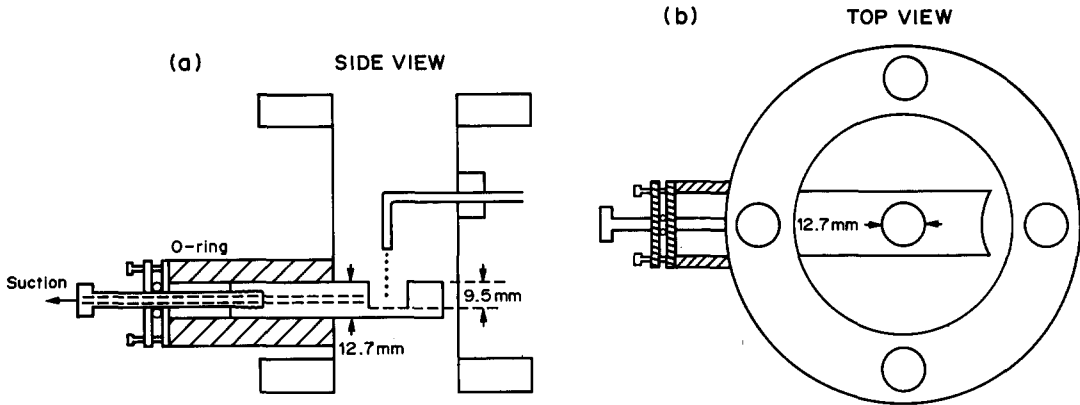

Figure 6. Plexiglas block with circular cavity.

Dry wall experiments were also carried out in the Plexiglas test section used in the wetted wall experiments. The droplets were allowed to deposit on the Plexiglas wall for approx. 15–20 min and then the entire test section was disassembled.

In order to obtain the amount of ink deposited at each location, the test section was inverted and a pre-measured amount of water, about 2.5 l., was poured into the first film withdraw unit several times. This way, water would flow out of the 2 mm holes and down along the pipe wall. After several washings a small sample was collected, and the remaining water was poured into the second film withdraw unit. There were two reasons for using the water from the previous wash: (1) because the amount of ink on the pipe wall between two withdraw units is minute, the ink content in 2.5 l. of water is too low to be accurately measured by the u.v. spectrophotometer, and (2) a cumulative deposition is desired for comparison of wet and dry wall results. This process was repeated until all the ink was washed off the Plexiglas pipe wall.

3. RESULTS

All experiments were performed with $50 \mu\text{m}$ droplets at a gas Reynolds number, based on the pipe diameter, of 30,610. Figure 7 presents measurements of the fraction of the droplets deposited as a function of axial distance from the injector. As was expected, a certain length of pipe was required before the droplets actually reached the pipe wall and began to deposit. The most interesting result is that the deposition is significantly smaller for a wall wetted with water than for a dry wall.

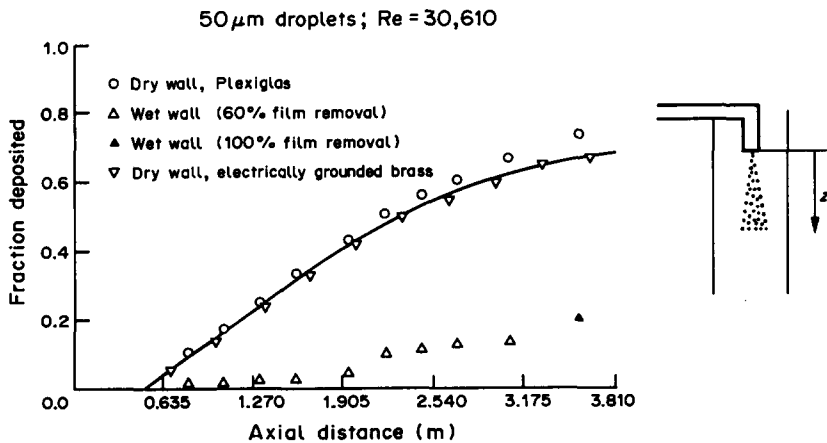

Figure 7. Comparison of deposition results with a dry and a wetted wall.

One possible explanation is that a poor average sample of the liquid film was obtained because the ink droplets and the liquid film were not well-mixed. Therefore, tests were conducted with a film scraping section (figure 8) that removed the film completely. The darkened point in figure 7 represents the measurement obtained with this section. It is noted that a significant difference from the experiment with a dry wall still exists. This would rule out any strong effects of poor sampling.

The most likely explanation is that the ink droplets bounced off the liquid film and did not coalesce with it. A mass balance confirmed that most of the ink droplets remained in the core when the wall was wetted with a liquid film. This was done by collecting and analyzing a liquid sample from the bottom of the separator.

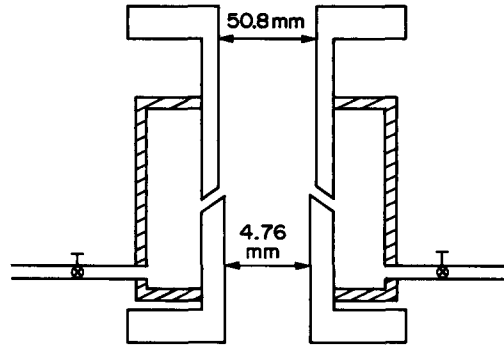

Figure 8. Section used to remove the film completely.

The observation of approximately the same deposition rates with a grounded brass wall and with a Plexiglas wall indicates that pipe material and electrostatic forces did not have significant effects.

Measurements of the type described here have been previously performed by Farmer *et al.* (1970), who studied the deposition of droplets from a central source on to the dry wall of a 12.70 mm lucite tube. In order to compare the two experiments, deposition constants, k_D , were calculated from the equation

$$\frac{dC_D}{dz} = -\frac{4k_D}{d_i U_B} C_D, \quad [3]$$

where C_D is the droplet concentration, U_B is the bulk gas velocity and d_i is the pipe diameter.

The integration of [3], assuming that k_D is constant, gives

$$\ln(1 - F_D) = -\frac{4k_D}{d_i U_B} (z - z_0), \quad [4]$$

where z_0 is the axial location where droplet deposition begins. A comparison of [4] with measurements is shown in figure 7 as a solid curve fitted to data by selecting $z_0 = 0.50$ m and $k_D = 43$ mm/s.

Exact comparison with the results of Farmer *et al.* (1970) is not possible because the two sets of experiments were done under different conditions. However, approximate agreement is noted if comparisons are made of the values of k_D/u^* , where u^* is the friction velocity, defined using the friction factor for a smooth pipe wall (see table 1 and figure 9). The abscissa in figure 9 is the dimensionless characteristic time

$$\tau^+ = \frac{d_p^2 u^{*2} \rho_G^2 \rho_L}{18 \mu_G^2 \rho_G}, \quad [5]$$

where μ_G is the viscosity of the gas, ρ_G is the density of the gas and ρ_L is the density of the liquid. The two solid lines were suggested by McCoy & Hanratty (1977) as a rough empirical fit of experimental results.

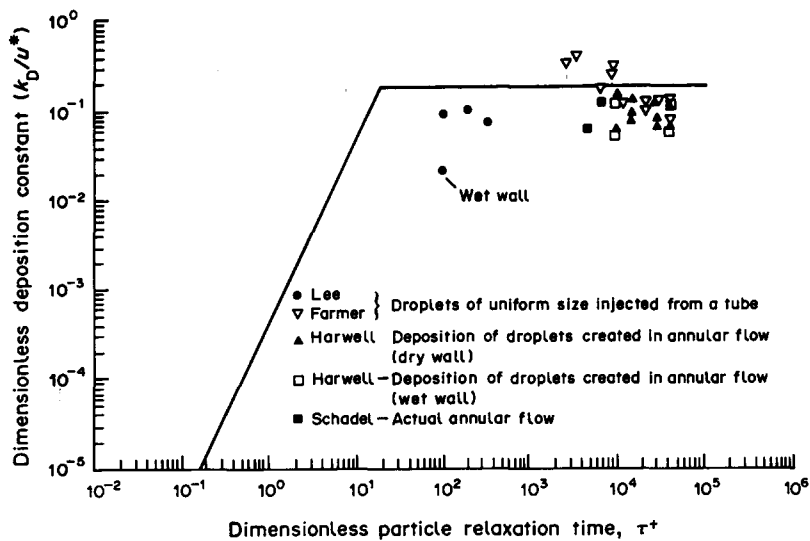

Figure 9. Deposition constants.

4. DISCUSSION

(a) Interpretation of the results

The experimental results presented above give clearcut evidence that $50 \mu\text{m}$ droplets entrained in an air flow moving at a centerline velocity of 11.6 m/s can bounce off the wall of a pipe if the wall is covered with a liquid film. The film used in the experiments was sufficiently thin ($155 \mu\text{m}$) that it did not atomize (Woodmansee & Hanratty 1969; Dallman *et al.* 1979; Cousins & Hewitt 1968) and such that large disturbance waves were not present (Andreussi *et al.* 1985a). A photograph of the film is shown in figure 10. It is not smooth but is covered with small capillary ripples.

In experiments currently in progress (as part of the Ph.D. Thesis of one of the authors) the component of the droplet velocity normal to the wall at distances $< 1/5$ of the pipe radius has been measured to be in the range of $0.1\text{--}0.7 \text{ m/s}$ for 85% of the droplets. This means that the droplets were approaching the wall at an angle of $0.5^\circ\text{--}3.5^\circ$. A characteristic Weber number can be defined in terms of the drop diameter, d_p , and its normal velocity component, v , as $We = \rho_L v^2 d_p / \sigma = 0.007$ to 0.34 . The results seem to be consistent with experiments by Jayaratne & Mason (1964) which showed that droplets hitting a water surface at glancing angles have a tendency to bounce.

(b) Comparison with annular flow studies

The results from this study seem contradictory to annular flow studies. Measurements of rates of deposition obtained by Schadel (1988) under actual annular flow conditions are shown in figure 9. It is noted that the rates of deposition are quite comparable to the deposition measurements on to a dry wall and much larger than the deposition measurements with a liquid film on the wall.

This difference can possibly be reconciled by recognizing two differences between the experiments reported in this paper and annular flows:

- (1) The droplets in an annular flow originate from the wall film. These droplets can move directly to other walls with a velocity component normal to the wall which is dictated by the atomization process. However, they can also be influenced by turbulent velocity fluctuations in the gas and take on characteristic velocities which are determined by gas-phase turbulence, as is the case for the experiments reported in this paper.
- (2) Annular flows usually have a different wave pattern on the liquid film than those seen in the experiments discussed in this paper. The chief difference is that the

large amplitude disturbance waves that exist in annular flows give rise to a much rougher surface for deposition.

Both of these effects would be expected to give larger deposition rates than was observed in the experiments with a wetted wall. Droplets originating from the film might approach the film with relatively large angles and, therefore, be less likely to bounce. Furthermore, the more roughened surface caused by the presence of disturbance waves could also enhance droplet coalescence with the wall film.

Experiments by Cousins & Hewitt (1968) also point out the difficulty of generalizing the results presented in this paper without experimentation over a wider range of conditions. Cousins & Hewitt removed the liquid film from the wall for an annular gas-liquid flow and determined deposition rates by measuring the buildup of the liquid film downstream of the withdraw unit. In most cases the film was completely removed. However, in a few experiments with a 9.525 mm pipe the liquid was only partially removed. In these cases the film was sufficiently thin so that no disturbance waves were present. Selected results from their experiments are given in table 1 and plotted in figure 9.

Firstly, it is noted that the k_D/u^* characterizing the results reported in this paper are in the range of values observed by Cousins & Hewitt (1968). Secondly, it is seen that the wet wall results are about the same as the dry wall results, indicating that droplet bouncing was not occurring. This conclusion received further support from rates of deposition determined from a knowledge of the drop size and visual studies of the rate at which droplets arrive at the wall film.

The differences between the results reported in this paper and those of Cousins & Hewitt are not understood. They could be due to differences in pipe diameter, differences in the pattern of droplet motion related to the method by which the droplets enter the gas flow or to differences

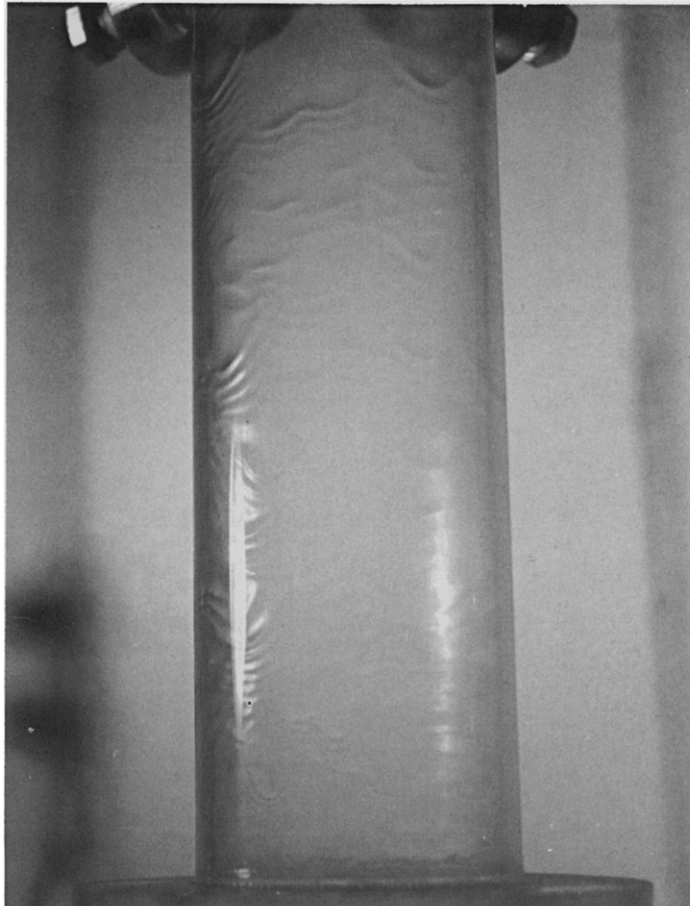

Figure 10. Photograph of the liquid film.

Table 1. Comparison of deposition constants obtained in different experiments

k_D (m/s)	u^* (m/s)	k_D/u^*	u_h (m/s)	d_i (mm)	d_p (μ m)	τ^+		
<i>Lee (1984): droplets from a central source</i>								
0.043	0.48	0.09	9.38	50.8	50	114		
0.068	0.698	0.10	13.30	50.8	50	231		
0.035	0.509	0.07	9.24	50.8	90	400		
0.00986	0.489	0.02 (wet wall)	9.35	50.8	50	114		
<i>Farmer (1970): droplets from a central source</i>								
0.604	1.600	0.38	28.35	12.7	93	4209		
0.305	1.017	0.30	16.92	12.7	126	3121		
0.482	1.865	0.26	33.83	12.7	126	10,500		
0.389	1.865	0.21	33.83	12.7	126	10,500		
0.207	1.865	0.11	33.83	12.7	197	25,660		
0.171	1.875	0.09	33.83	12.7	197	25,660		
0.152	1.017	0.15	16.92	12.7	197	7629		
0.207	1.865	0.11	33.83	12.7	262	45,400		
0.126	1.865	0.07	33.83	12.7	262	45,400		
0.176	1.600	0.11	28.35	12.7	262	33,400		
0.117	1.017	0.11	16.92	12.7	262	13,500		
<i>Cousins & Hewitt (1968): deposition of droplets created by an annular flow</i>								
0.137	1.488	0.092 (dry wall)	32.90	31.75	70-204	17,190		
0.180	1.994	0.090 (dry wall)	46.00	31.75	70-204	30,864		
0.189	1.483	0.127 ^a (dry wall)	32.80	31.75	70-204	17,070		
0.119	1.478	0.08 ^b (dry wall)	32.80	31.75	70-204	16,950		
0.232	1.991	0.116 ^a (dry wall)	45.90	31.75	70-204	30,760		
0.149	1.994	0.075 ^b (dry wall)	45.90	31.75	70-204	30,864		
0.183	1.194	0.153 ^a (dry wall)	21.60	9.525	70-204	11,055		
0.137	1.194	0.115 ^a (wet wall)	21.60	9.525	70-204	11,055		
0.064	1.187	0.054 ^b (dry wall)	21.45	9.525	70-204	10,926		
0.058	1.187	0.049 ^b (wet wall)	21.45	9.525	70-204	10,926		
0.235	2.476	0.095 ^a (dry wall)	49.75	9.525	70-204	47,557		
0.241	2.476	0.097 ^a (wet wall)	49.75	9.525	70-204	47,557		
0.158	2.487	0.0637 ^b (dry wall)	50.00	9.525	70-204	48,015		
0.158	2.487	0.0637 ^b (wet wall)	50.00	9.525	70-204	48,015		
<i>Schadel (1988): actual annular flow with equal deposition and atomization rates</i>								
		u_h^* (cm/s)	k_D/u_h^*		Estimated average			
0.278	1.629	2.263 ($f_i = 0.01$)	0.17	0.12	32.00	25.4	90	7885
0.265	3.070	4.174 ($f_i = 0.008$)	0.08	0.06	66.00	25.4	40	5300

^aShort deposition length 0.152 m for $d_i = 9.52$ mm and 0.343 m for $d_i = 31.75$ mm.

^bLong deposition length 1.067 m for $d_i = 9.52$ mm and 2.86 m for $d_i = 31.75$ mm.

in wave pattern. Although disturbance waves were not present, photographs of the film that existed in the experiments of Cousins & Hewitt indicate a much rougher interface than that shown in figure 10. It is clear that studies must be carried out over a wider range of conditions before any general statements can be made regarding the occurrence of droplet bouncing.

(c) Studies of critical quality

It appears however, that droplet bouncing is possible and is most likely to occur when the wall film is sufficiently thin that it has no disturbance waves and when the droplets are being dispersed primarily by fluid turbulence. Consequently, the phenomenon could have some bearing on understanding the observation by a number of researchers (Kitto 1980; Owen 1986) that in a heated tube there is a critical quality at which there is a sharp decrease in the heat flux.

Doroschuk & Nigmatulin (1971) have argued that once the wall film is reduced to the condition where roll waves do not exist, the heat flux causes droplet deposition to be suppressed by vapor flowing normally from the remaining film. They supported this argument by experiments in which they observed that salt-laden droplets injected into the heated region did not deposit on the wall. Hewitt (1970) and Keeys *et al.* (1970) carried out experiments which suggest, however, that heating the wall film does not suppress deposition.

Owen (1986) recently reevaluated experiments related to the critical quality phenomena with the help of extensive data now available on entrainment in adiabatic flows. He supported the notion of a suppression of droplet deposition put forth by Doroschuk & Nigmatulin (1971). However, in view of the results of Hewitt & Hall-Taylor (1970), he argued that this resulted from the suppression of gas-phase turbulence by the droplets.

The results presented in this paper offer the possibility of another interpretation. They show that deposition onto thin liquid wall films can be inhibited by droplet bouncing. In the heat transfer region where the critical quality phenomenon occurs, the wall film is sufficiently thin that roll waves do not exist. Also, in this region the percentage of droplets fully entrained by the gas-phase turbulence is probably larger than in the annular flow regions where the film is agitated by large roll waves.

Acknowledgements—This work has been supported by the National Science Foundation under Grant NSF CBT 85-19098, by the Shell Companies Foundation and by the Department of Energy under Grant DFF G02-86E R 13556.

REFERENCES

- ADAM, J. R., CATANEO, R. & SEMONIN, R. G. 1971 The production of equal and unequal size droplet pairs. *Rev. scient. Instrum.* **42**, 1847–1849.
- ANDREUSSI, P., ASALI, J. C. & HANRATTY, T. J. 1985a Initiation of roll waves in gas–liquid flows. *AIChE JI* **31**, 119–126.
- ANDREUSSI, P., AZZOPARDI, B. J. & HANRATTY, T. J. 1985b Special Issue: two-phase annular and dispersed flows. *PhysicoChem. Hydrodynam.* **6**, 1–281.
- COUSINS, L. B. & HEWITT, G. F. 1968 Liquid phase mass transfer in annular two-phase flow: droplet deposition and liquid entrainment. UKAEA Report No. AERE-R5657.
- DALLMAN, J. C., JONES, B. G. & HANRATTY, T. J. 1979 Interpretation of entrainment measurements in annular gas–liquid flows. In *Two-phase Momentum, Heat and Mass Transfer in Chemical, Process and Energy Engineering Systems*, Vol. 2 (Edited by DURST, F., TSIKLAURI, G. V. & AFGAN, N. H.), pp. 681–693. Hemisphere, Washington, D.C.
- DOROSCHUK, V. E. & NIGMATULIN, B. I. 1971 Critical heat transfer of the second kind in a vertical tube at low pressures. *Therm. Engng* **18**(3), 117–119.
- FARMER, R., GRIFFITH, P. & ROHSENOW, W. M. 1970 Liquid droplet deposition in two-phase flow. *Trans. ASME JI Heat Transfer* 587–594.
- GINSBERG, T. 1970 Droplet transport in turbulent pipe flow. Ph.D. Thesis in Nuclear Engineering, Pennsylvania State Univ., State College, University Park, Pa.
- HENSTOCK, W. H. 1977 The effect of a concurrent gas flow on gas–liquid mass transfer. Ph.D. Thesis in Chemical Engineering, Univ. of Illinois, Urbana, Ill.
- HEWITT, G. F. 1970 Experimental studies on the mechanism of burnout in heat transfer to steam–water mixtures. *Proc. 4th Int. Heat Transfer Conf., Paris* **6**, Paper B6.6.
- HEWITT, G. F. 1981 Burnout. In *Two-phase flow and Heat Transfer in the Power and Process Industries* (Edited by BERGLES, A. E., COLLIER, J. G., DELHAYE, J. G., HEWITT, G. F. & MAYINGES, F.), pp. 256–281. Hemisphere, Washington, D.C.
- HEWITT, G. F. & HALL-TAYLOR, N. S. 1970 *Annular Two-phase Flow*, pp. 136–169, 219–250. Pergamon Press, Oxford.
- JAYARATNE, O. W. & MASON, B. J. 1964 The coalescence and bouncing of water drops at an air/water interface. *Proc. R. Soc. (Lond.)* **A280**, 545–565.
- KEEYS, R. F. K., RALPH, J. C. & ROBERTS, D. N. 1970 The effect of heat flux on liquid entrainment in steam–water flow in a vertical tube at 100 PSI (6.894×10^6 N/m²). UKAEA Report No. AERE-R6294.
- KITTO, J. B. 1980 Critical heat flux and the limiting quality phenomenon. *AIChE Symp. Ser.* **76**, No. 199, pp. 57–78.
- LEE, M. M. 1984 Droplet dispersion in vertical turbulent pipe flow. M.S. Thesis, Univ. of Illinois, Urbana, Ill.

- McCOY, D. D. & HANRATTY, T. J. 1977 Rate of deposition of droplets in annular two-phase flow. *Int. J. Multiphase Flow* **3**, 319–331.
- McCOY, D. & HANRATTY, T. J. 1979 Droplet mixing and deposition in a turbulent flow. In *Two-phase Momentum, Heat and Mass Transfer in Chemical, Process, and Energy Engineering Systems*, Vol. 1 (Edited by DURST, F., TSIKLAURI, G. V., & AFGAN, N. H.), pp. 119–132. Hemisphere, Washington, D.C.
- OWEN, D. G. 1986 An experimental and theoretical analysis of equilibrium annular flows. Ph.D. Thesis in Chemical Engineering, Univ. of Birmingham, England.
- SCHADEL, S. A. 1988 Atomization and deposition rates in vertical annular flow. Ph.D. Thesis, Univ. of Illinois, Urbana, Ill.
- SCHNEIDER, J. M., LINDBLAD, N. R., HENDRICKS, C. D. & CROWLEY, J. M. 1967 Stability of an electrified liquid jet. *J. appl. Phys.* **30**, 2599–2605.
- TATTERSON, D. F. 1975 Rates of atomization and drop size in annular two-phase flow. Ph.D. Thesis in Chemical Engineering, Univ. of Illinois, Urbana, Ill.
- VAMES, J. S. 1982 Droplet dispersion in a turbulent pipe flow. M.S. Thesis in Chemical Engineering, Univ. of Illinois, Urbana, Ill.
- VAMES, J. S. 1985 Droplet dispersion in a turbulent pipe flow. Ph.D. Thesis, Univ. of Illinois, Urbana, Ill.
- WOODMANSEE, D. E. & HANRATTY, T. J. 1969 Mechanism for the removal of droplets from a liquid surface by a parallel air flow. *Chem. Engng Sci.* **24**, 299–307.